



www.simtrum.com



www.simscop.com

Company Introduction

We focus on microscopy and spectroscopy.



SIMTRUM.Pte.Ltd

**Singapore - A Global E-commerce Platform for
Microscopy and Spectroscopy**



SIMSCOP (GZ) .Ltd

**Guangzhou, China - R&D and Production
Center for High-end Microscopes**

COMPANY PROFILE

Vision

To be a leading photonics technology company that truly understands and adds value to our customers.

Mission

Driven by innovation, we deliver exceptional services and precise products to global photonics users, empowering customer success and advancing industry transformation.

Company-Milestone

The official visit of the Prime Minister of Singapore and the Governor of Guangdong Province



Completed Seed Round investment



Founded in 2018, AngelCentral has trained 1,000+ angel investors,

Launched Widefield Microscopy, Confocal Raman, PL System

Provide customized microscopy solutions.



Pre-A Investment

SG INNOVATE is Singapore government-owned deep tech innovation and has invested in about 100+ Companies.

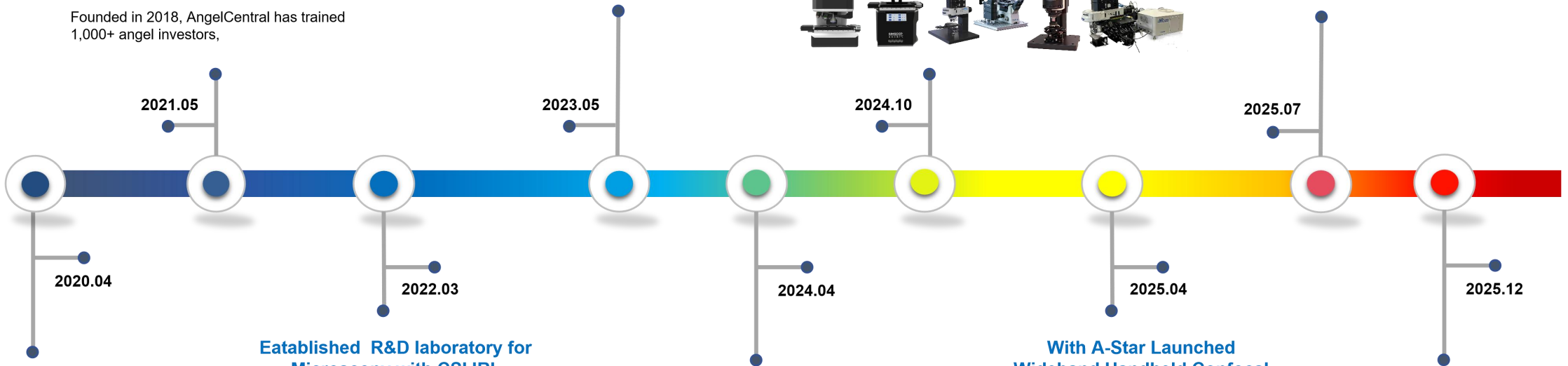

2020.04

Simtrum E-commerce Platform Established

Focus on microscopy and spectroscopy e-commerce platform, Covers 7 product series with 6,000+ products



2021.05

2023.05

2024.10

2025.07

2022.03

Established R&D laboratory for Microscopy with CSIJRI

CSIJRI is a China-Singapore joint international science and technology platform, co-built by SCUT and NTU Singapore under the witness of leaders from both countries..



2024.04

Launched Laser Confocal Microscope

Committed to filling the gap in domestic high-end microscopes.



With A-Star Launched Wideband Handheld Confocal Raman Skin Analyzer

Initiated commercial cooperation with research institutions.

2025.12

Launched Microscope Components

Reduce costs, improve efficiency, and flexibly integrate with various systems.



Laboratories and awards



R&D Laboratory

The joint R&D laboratory for microscopes, co-established with the China-Singapore Research Institute, is equipped with independent R&D and production capabilities, dedicated to innovating and making breakthroughs in cutting-edge optical technologies.



Awards and IP Patents

Participated in the finals of the Guangzhou Technology Innovation and Entrepreneurship Competition, won the championship in the startup group, and obtained multiple technical patents and certificates!

Key Leadership and Business Delegations



Singapore Prime Minister Lee Hsien Loong visits the company on March 29, 2023



Governor of Guangdong Province visits the company's related products on April 19, 2023



Former Secretary of the Guangzhou Municipal Party Committee visited

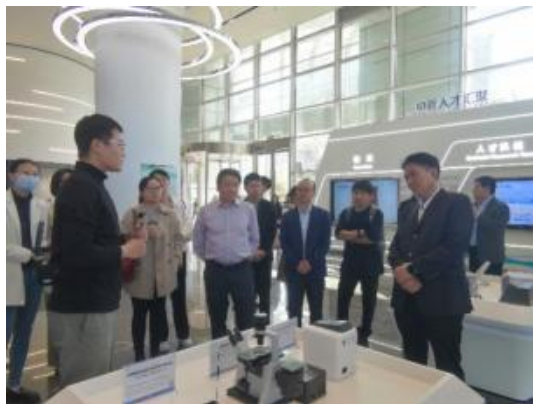

President of the Chinese Academy of Social Sciences Visits



Director Yan from the Chinese Ministry of Science and Technology visited



Former Deputy Prime Minister of Singapore, Ong Teng Cheong, paid a visit

Microscopy + Spectroscopy Technical Capabilities

Core Technical Capabilities

- Optical component and overall optical path design
- Optoelectronic detectors, driver, and other PCB design
- Optomechanical components and complete machine design
- Software design and development

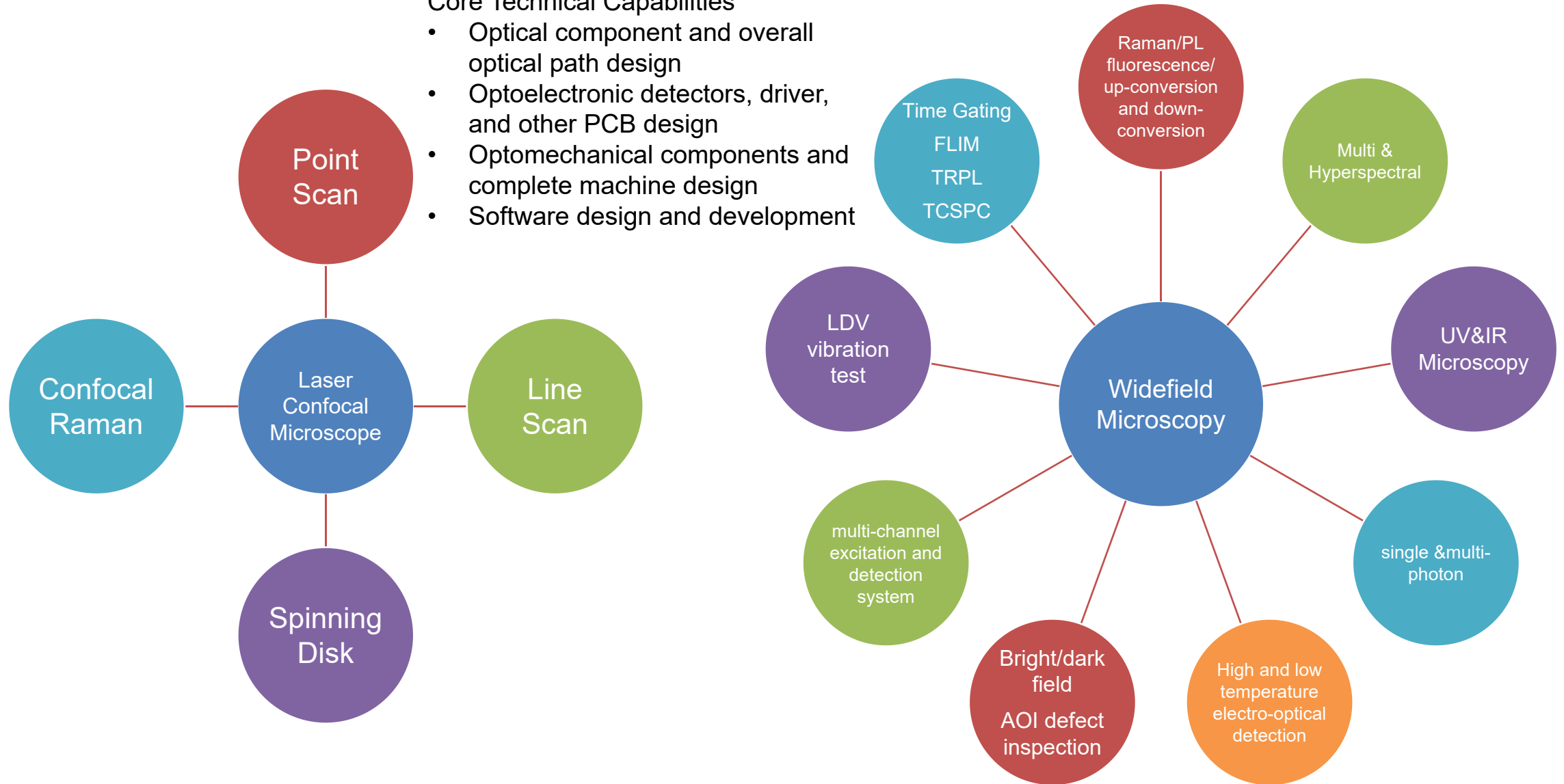

Laser Confocal Microscopy



Parameter	Point Scan Confocal	Point Scan Confocal with Raman	Line Scan Confocal	Spindisk Basic
Frame Rate	4fps-12fps@512x512	4fps-12fps@512x512	50fps@1024x1024	100fps@2048x2048
Resolution	~230 nm	~230 nm	150-200nm	~230 nm
Depth	<100μm	<100μm	<600μm	<200μm
Detector	SIPM/PMT	SIPM/PMT + Raman	sCMOS	sCMOS
Application	Biomedicine: Three-dimensional fluorescence microscopy, observation of cells and tissues, multi-channel fluorescence detection		Rapid 3D imaging of thick tissues, 3D image detection of tissue pathology, 3D tissue morphology research of small animal tissue organs such as brain neurons, liver, kidney, etc	Dynamic fluorescence imaging of living cells/tissues, microscopic observation of small animals such as zebra fish and nematodes

WideField or Confocal Raman, PL System



Upright Raman System



Inverted Raman System

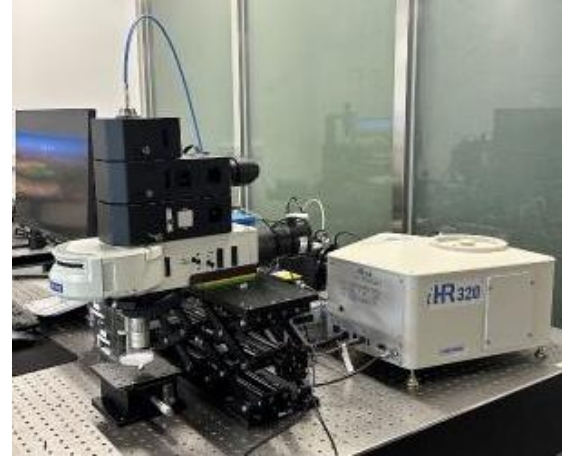

PL with Horiba

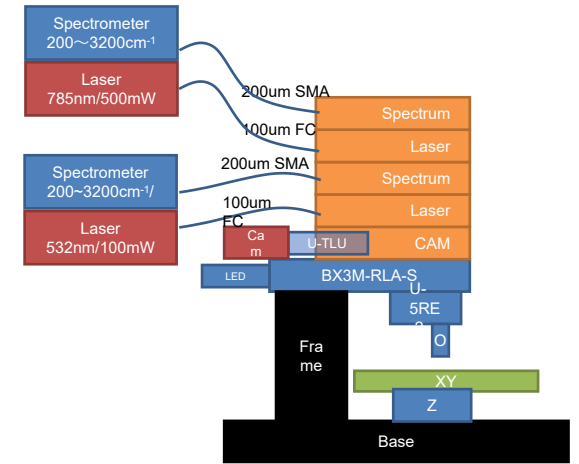

Optical Path of Raman



Tabletop Raman



Fiber Output Raman



Portable Raman



Handheld Raman

Multimodal Microscope (2026 New Product)



Core Product Advantages

Upright excitation: Suitable for films, cells, and solid materials.

Side excitation: Compatible with dynamic stirring of solution-phase materials and supports high-throughput screening.

Inverted excitation: No sample obstruction, suitable for live cell culture dishes and tissue slices.

Laser upright: High-resolution imaging, used for organelle structure localization.

LED upright: Low heat and low toxicity, supports long-term observation of live cells.

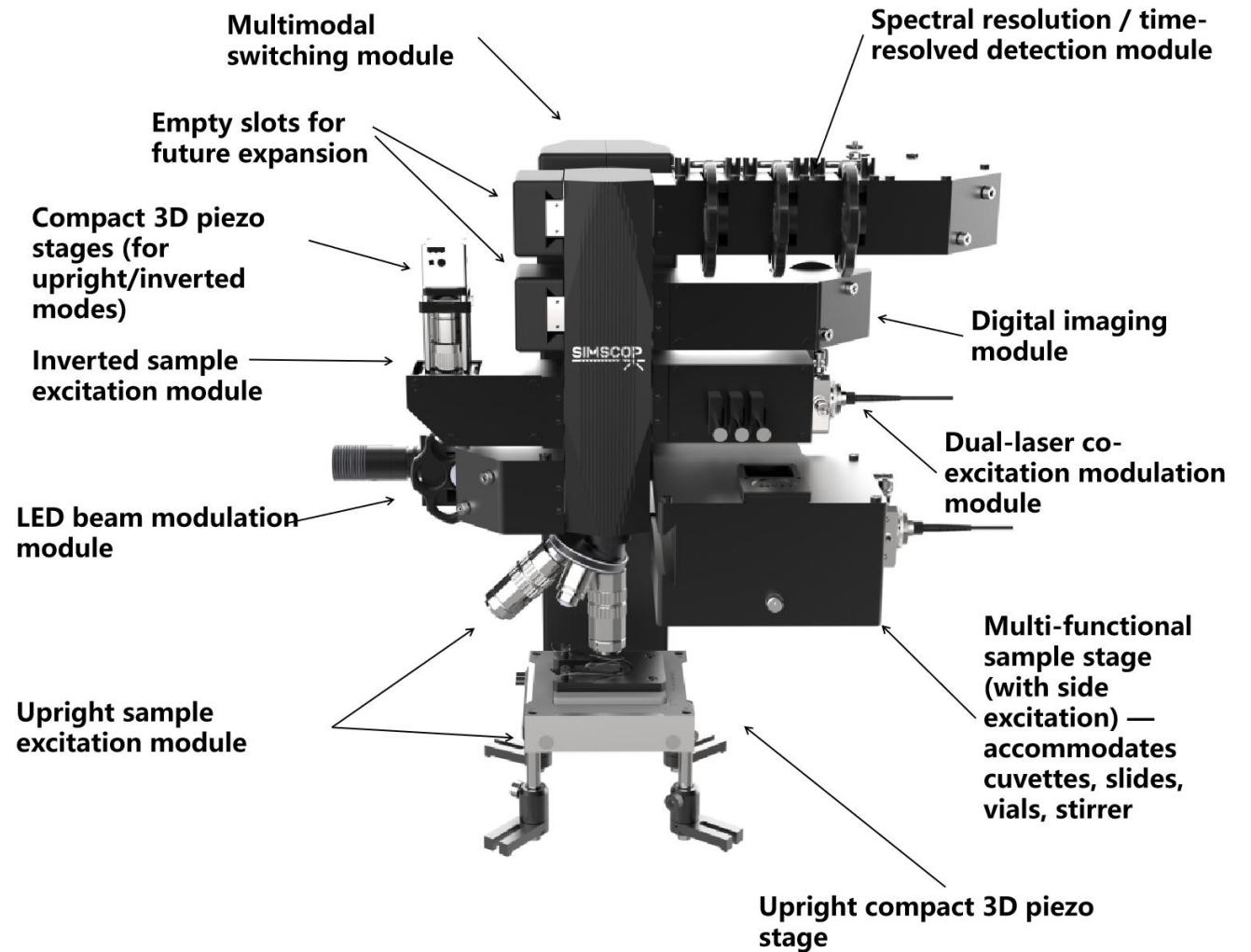

Multimodal Microscope (2026 New Product)



SIMSCOP-Mat



SIMSCOP-Bio



SIMSCOP-HTS

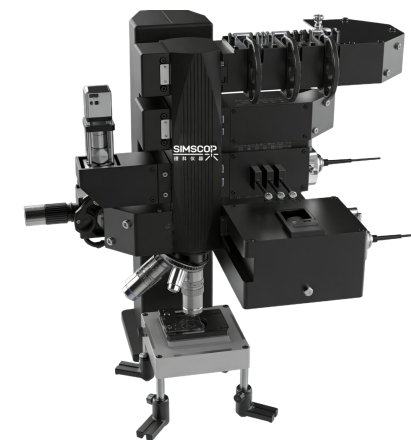

SIMSCOP-Pro

Model	Corresponding Module Combination	Software Preset Focus	Typical application scenarios
SIMSCOP-Mat (Material Dynamics Type)	Dual-laser cooperative excitation modulation module Spectral resolution acquisition module Time-domain response acquisition module Multifunctional sample stage (including side excitation) LED beam modulation module Sample upright excitation	<ul style="list-style-type: none"> • Default open lifetime spectral synchronization interface • Pre-set rare-earth ion templates (such as Tm^{3+} /Er^{3+}) • Automatic laser delay matching 	Measure the 3H_4 energy level lifetime of $NaYF_4 : Yb, Tm$ upconversion materials and simultaneously obtain the emission spectra
SIMSCOP-Bio (biological imaging type)	LED beam modulation module Inverted sample excitation module Digital image acquisition module Upright sample excitation	<ul style="list-style-type: none"> • Low-light toxic imaging mode is enabled by default • Time-lapse photography wizard (set interval/total duration) • One-click access to ROI cell tracking tool 	Perform dynamic tracking of NIR fluorescent probes on adherent HeLa cells for 8 hours, imaging every 10 minutes.
SIMSCOP-HTS (High-throughput screening type)	Multifunctional sample stage (with side excitation) LED beam modulation module Upright sample excitation Digital image acquisition module	<ul style="list-style-type: none"> • Built-in 96-well plate coordinate template • "One-click full plate scan" shortcut button • Automatic export of well-intensity CSV report 	Perform batch fluorescence intensity screening of perovskite quantum dot solutions with different ratios in a 96-well plate
SIMSCOP-Pro (Full-mode Research-oriented)	Dual-laser cooperative excitation modulation module Spectral resolution acquisition module Time-domain response acquisition module Digital image acquisition module Multi-functional sample stage (including side excitation) Inverted sample excitation module LED beam modulation module Upright sample excitation	<ul style="list-style-type: none"> • Full-featured control panel access • Supports Python scripting and API calls • Multi-modal synchronized trigger configuration wizard 	Simultaneously collect lifetime images under laser excitation, wide-field images under LED excitation, and emission spectra of live cell samples

STED Super-Resolution Microscope

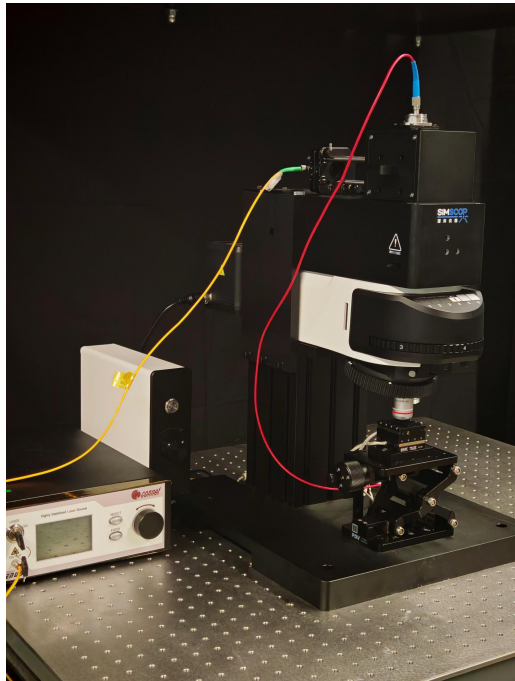

2-channel STED super-resolution microscope

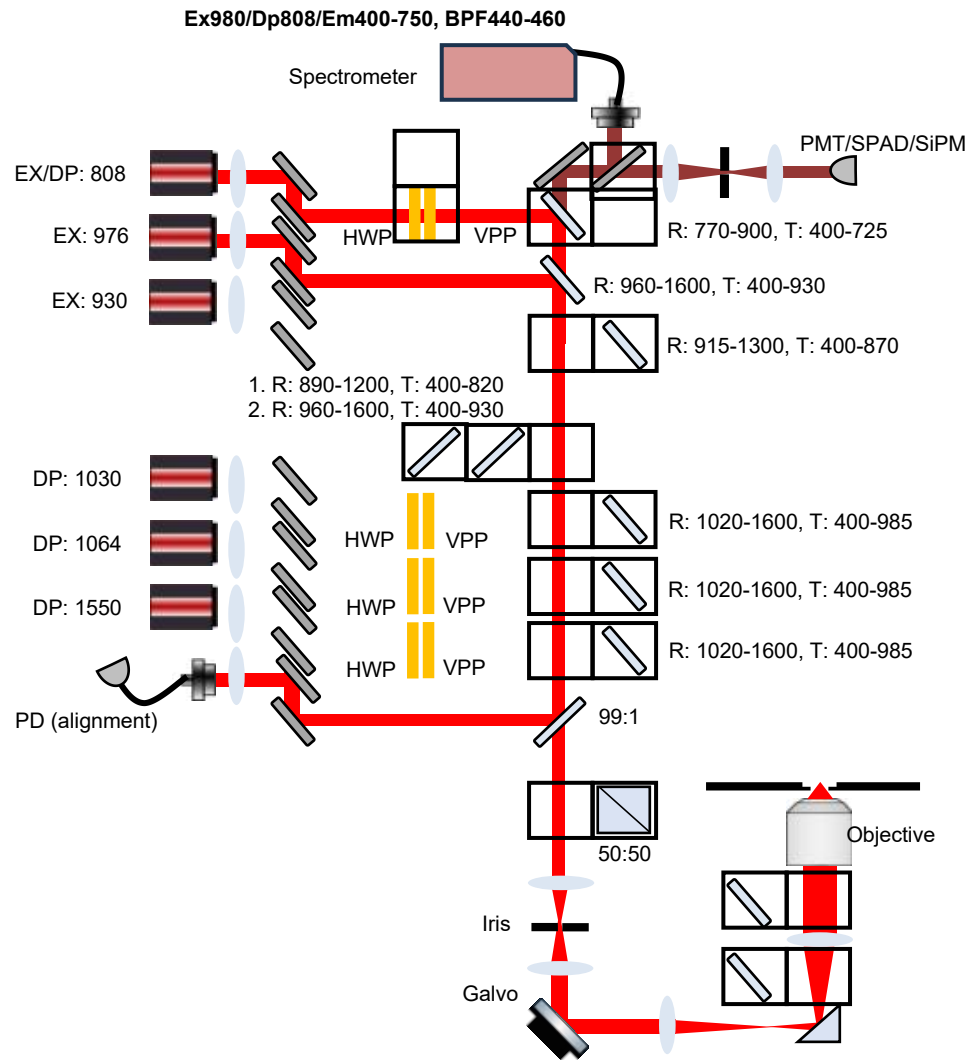

6-channel STED super-resolution microscope

Sample: Monodisperse nanoparticles, rare-earth upconversion nanoparticles, very weak light, nanoparticle fluorescence peak around 450 nm, quenched at 808 nm

Requirements:

- Three sets of 980E 808S, 980E 1550S, 808E 1064S are needed.
- Need to achieve manual replacement combinations of 4 types of lasers, requiring stable direct use without frequent adjustments.
- 980 single-mode CW P=10-50mW LW=1nm,
- 808 single-mode CW P=50-100mW LW=1nm,
- 1550 single-mode CW P=10-50mW LW=1nm,
- 1064 single-mode CW P=50-100mW LW=1nm.
- E excitation does not need to be very high, just a few milliwatts, S can be higher, 50-100mW.
- Sample lifetime is milliseconds to hundreds of microseconds, laser TLL = 1 microsecond pulse.
- At least 3 phase plates.

Motorized Upright & Inverted Microscope



Upright Motorized
Microscope

Inverted Motorized
Microscope



Point Scan Confocal Module



Line Scan Confocal Module



Spindisk Confocal Module



SIM Module



Auto Multi-channel fluorescence,
Raman, PL



Auto Line/Point scanning confocal

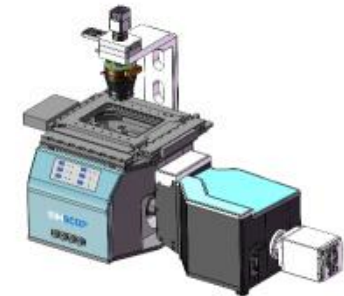

Auto Spin Disk Confocal



Jointly developed products with research institutions in China and Singapore



Broadband Handheld Confocal Raman Skin Analyzer



Maskless UV lithography machine

Parameter	DermDive Supreme Series
Detection range	FP: 450 – 1750cm ⁻¹ ; HW: 2800-3750cm ⁻¹
Axial resolution	10um~20um
Stratum corneum thickness measurement	up to 200nm
Sensitivity	60dB
Scan Time	2-10s/depth
Probe Size	~12 cm × 6 cm × 5 cm
Probe Weight	~800g
Device size	~ H: 1m, W: 50cm, L: 50cm
Equipment Weight	~ 40kg
Raman Spectroscopy Database	Natural Moisturizing Factors (NMF): Pyrrolidone carboxylic acid, ornithine, serine, proline, glycine, histidine, alanine, ceramide, keratin, lactic acid, urea, urocanic acid, moisture content
Other parameters	Professional stratum corneum thickness testing, efficient chemical penetration depth assessment, personalized chemical substance testing services

Product Model	LL-LW-405-4-0.8*	LL-LW-405-6-0.8*			
Reproducibility	0.1 μm				
Autofocus	Piezoelectric drive; fast and precise (20 nm) focusing; compatible with most transparent substrates				
Wafer alignment	Automatic wafer alignment				
	Top only	Top and bottom (optional)			
Maximum Write Field	106×106 mm	150×150 mm (8"optional)			
Maximum sample size	130 mm × 130 mm (5"Compatible)	155 mm × 155 mm (6"Compatible)			
Sample Installation Method	Friction mounting (optional: porous vacuum suction cup)				
Weight	20 kg	27 kg			
System size	330×310×340 mm	342×385×338 mm			
Objective lens		50X	20X	10X	5X
	Minimum line width (μm)	0.5	0.8	1.5	3
	Patterned speed (mm ² /min)	3	15	60	200
	Laser exposure wavelength	405 nm (365/385 nm optional); supports software-selected dual wavelengths (optional)			
Grayscale	8 bits (16 bits optional)				
Software	Supported file formats	.bmp, .png, .tiff, .dxf, .gds, The pattern can be drawn directly in the software.			
	Pattern Design	Beam Xplorer			
	Drawing	KLayout (Most powerful function) , AutoCAD			

Our capabilities regarding the core components related to microscopy and spectroscopy

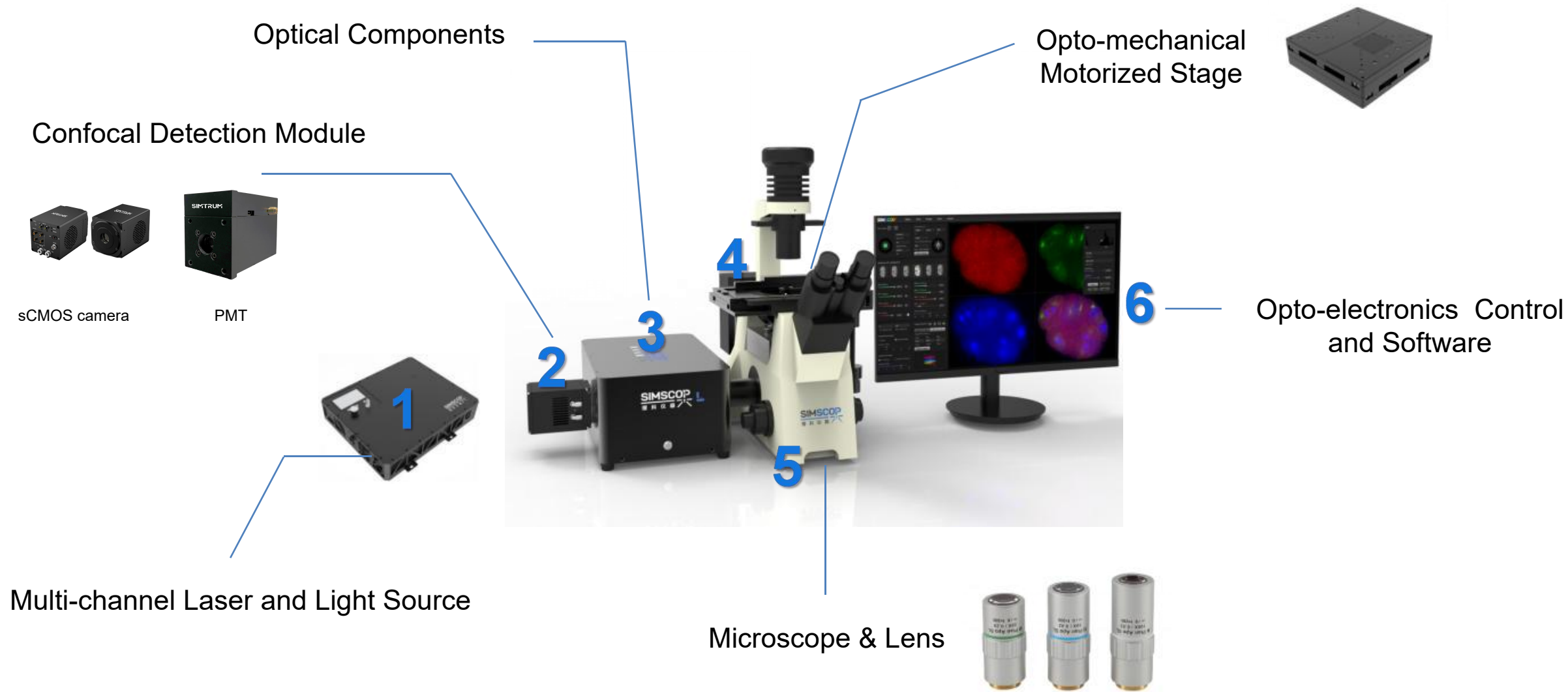

Laser/Light source



**Supercontinuum laser,
tunable wavelength 450-
2400nm**



**4-6 Channel Single-Mode
Laser 405 to 640nm**



**4-8 Channel
Multimode Laser
405 to 640nm**



**Narrow linewidth
semiconductor lasers
532, 780, 1064 nm**



**Single-wavelength and
multi-wavelength LEDs
360 to 780nm**



**Laser Speckle Dissipation
Homogenizer**

Detector /Spectrometer



**Silicon photomultiplier
(SIPM)
(300-950nm)**



**Single Photon Detector
(SPD)
(200-1700nm)**



**Photomultiplier Tubes
(PMT)
(160-900nm)**



**Photodiode Detector
(PD)
(200nm-12um)**



**spectrometer
200-2500nm**



**multi-channel
spectrometer
200-2500nm**



**High-throughput
spectrometer 200-
2500nm**

Optomechanics Series



Optical Heating & Cryo Stage



Electrical Probe Temperature Stage



Adjustable Electrical Probe Station



In-situ Tensile Heating & Cryo Stage

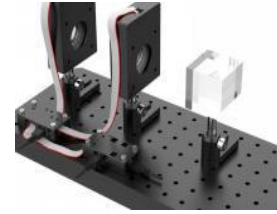

Electric Phase Shift Disc Rotor



High-speed electric filter wheel 200ms

Launch in 2026

Electric high-speed shutter

Opto-Electronic



AOM



Electro-optic Intensity Modulator



AOTF



Tunable Multi-channel Phase-coherent Radio Frequency Signal Source

Radio frequency generator (synchronizable)
12 slots with 6 in use, DDS core, 1GSps



Time counter 1 picosecond level Time Tagger

E-commerce platform specializing in microscopy and spectroscopy

- English and Chinese e-commerce platforms (www.simtrum.com)
- Product Line card ([Download](#))
- The platform covers 7 product series with approximately 6,000 products.
 - microscope
 - spectral analysis
 - Lasers and light sources
 - imaging
 - optoelectronics
 - Optomechanics
 - Optical Devices & Optical Components
- The application fields of the platform cover (Optical Application Product Line Card)
 - Biomedical and Life Sciences
 - 2D Material and Semiconductor
 - Quantum
 - Terahertz

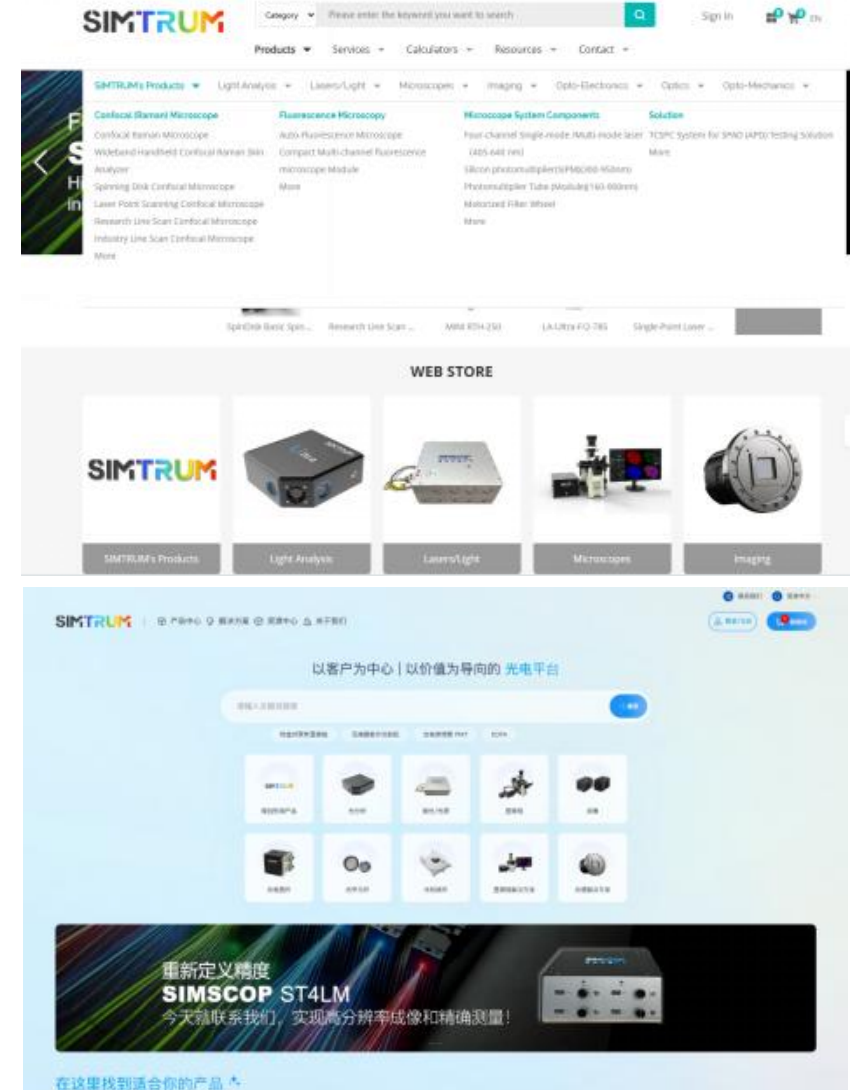

Our Customers

Scientific research clients



Industrial clients





<http://www.simtrum.com>

Email: info@simtrum.com

Contact Singapore : +65 6996 0391

Contact China :+86 133 2643 0008